

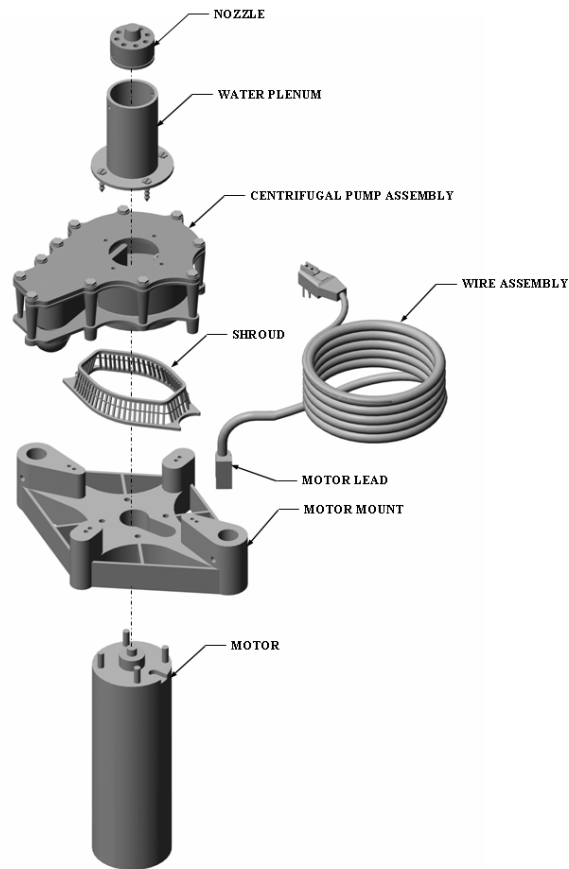

THE WATER'S EDGE™

LEGACY CENTRIFUGAL PUMP SHROUD AND PUMP REPLACEMENT



!WARNING: RISK OF ELECTRIC SHOCK, DISCONNECT POWER PRIOR TO SERVICING

STEP 1 Place the fountain upright with the motor resting on a stable surface. CAUTION: Do not allow the unit to fall over as damage may occur.

STEP 2 Remove the water plenum, nozzle assembly and gasket by removing the four 1/4-20 hex head cap screws from the flange of the water plenum.

STEP 3 Remove the four 1/4-20 hex head cap screw that attach the pump to the motor mount. Remove the pump by pulling upward with a rocking motion to lift pump from the motor.

STEP 4 Remove the shroud and clean all debris from the motor mount and motor shaft. Inspect the unit for any other damage.

STEP 5 Install new shroud.

STEP 6 Install new pump assembly by aligning the impeller hub to the motor shaft and pushing downward onto the motor shaft.

STEP 7 Align the four pump mounting holes to the four holes of the motor mount and install the four 1/4-20 hex head cap screws and tighten to 50-55 in/lbs.

STEP 8 Reinstall the gasket, water plenum and nozzle assembly.

Page 2 of 2