



"THE WATER'S EDGE"

**8100-04 Paseo, Kansas City, Missouri 64131
800-821-3177**

INSTALLATION

OPERATION

AND

MAINTENANCE

OF THE

FONT'N-AIRE "LEGACY" FLOATING FOUNTAINS

This manual is designed to aid in the installation; operation and maintenance of Font'N-Aire "Legacy" floating fountains. **Do not dispose of this manual!** Provide to this manual to the owner.

The following information is provided to alert persons to potential personal injury hazards inherent with products.

! DANGER: Indicates an eminently hazardous situation which, if not avoided, will result in death or serious injury.

! WARNING: Indicates a potentially hazardous situation which, if not avoided, could result in death or serious injury.

! CAUTION: Indicates a potentially hazardous situation which may result in minor or moderate injury.

January 2, 2007



SAFETY DATA INFORMATION SHEET

- ! DANGER:** RISK OF ELECTRIC SHOCK. DO NOT INSTALL THIS EQUIPMENT IN SWIMMING AREAS. THIS EQUIPMENT HAS NOT BEEN INVESTIGATED FOR USE IN SWIMMING AREAS.
- ! WARNING:** DISCONNECT AND LOCK OUT ELECTRICAL POWER BEFORE ANY SERVICE IS PERFORMED ON THIS DEVICE.
- ! WARNING:** THE CONTROL PANEL AND UNIT MUST BE GROUNDED. FAILURE TO CONNECT TO A PROPER GROUND COULD RESULT IN PERSONAL INJURY OR DEATH.
- ! WARNING:** BEFORE ATTEMPTING TO INSTALL, SERVICE OR MAINTAIN THE UNIT AND / OR FLOTATION IN ANY BODY OF WATER A COAST GUARD APPROVED PERSONAL FLOTATION DEVICE (PFD, TYPE III OR HIGHER) MUST BE WORN.
- ! WARNING:** THE FLOTATION PROVIDED FOR THIS EQUIPMENT, HAS NOT BEEN INVESTIGATED PERSONAL FLOTATION DEVICE.
- ! WARNING:** ATTEMPTING TO INSTALL OR SERVICE EQUIPMENT FROM AN UNSTABLE WORK PLATFORM COULD RESULT IN DEATH OR INJURY.
- ! WARNING:** POSSIBLE CUTTING HAZARD. ROTATING PROPELLER COULD RESULT IN SERIOUS INJURY. TURN OFF POWER AND LOCK OUT BEFORE INSTALLATION OR SERVICING.

DO NOT OPERATE THIS EQUIPMENT OUT OF THE WATER!

(EXCEPTION:) IT IS PERMISSABLE TO BUMP RUN 3-PHASE EQUIPMENT OUT OF THE WATER TO VERIFY COUNTER CLOCKWISE MOTOR ROTATION WITH A RAPID ON / OFF-OPERATION.

- ! CAUTION:** INSTALLATION OR SERVICE WORK MUST BE PERFORMED FROM A STABLE WORK PLATFORM TO AVOID THE POSSIBILITY OF CAPSIZING.



'THE WATER'S EDGE'

FONT'N-AIRE "LEGACY"

ASSEMBLY AND INSTALLATION INSTRUCTIONS

! WARNING: DO NOT INSTALL OR USE THIS DEVICE IN SWIMMING AREAS

Legacy fountains are shipped pre-assembled for a better understanding of how the unit should appear when installed. It will be necessary to remove the individual components to aid in the removal of the fountain from the shipping carton.

- STEP 1 Remove the cartons labeled "Time Clock / E. L. C. I." and Nozzle / F. R. D. Set them aside for now
- STEP 2 Remove the upper packing foam and the Font'N-Aire Legacy unit from the shipping carton as well as the Support Chamber and float. Set these items aside making certain that the unit is not allowed to topple over. ***Do not dispose of the shipping container and packing in the unlikely event of return for service. SAVE THE PACKING!***
- STEP 3 Re-insert the Support Chamber into the flotation if it was removed while unpacking the shipping carton. (If a light kit was purchased with the unit, install the lighting immediately before installing the fountain in the pond.)

INSTALLATION

MOORING OF FLOAT

!WARNING: DO NOT USE AS A PERSONAL FLOTATION DEVICE.

- STEP 1 To anchor: Cut 2 lengths of 1/4" polyethylene rope (user supplied), allowing for 2 to 3 feet of rope for every foot of water depth. Most commonly the unit is anchored by two 8" x 8" x 16" concrete building blocks (one per corner diagonally). See the enclosed suggested mooring drawing.
- STEP 2 Insert one rope end into one of the molded holes in the float and tie off. Do the same on the opposite diagonal corner. Only two opposing corners are needed for secure mooring.
- STEP 3 The mooring ropes, as an alternative, may be tied off to the shore. Be certain to allow for variations in water level when determining shore mooring rope length.
- STEP 4 Place the Legacy fountain into the flotation. No mounting hardware is needed or required.



ELECTRICAL

ALL ELECTRICAL CONNECTIONS SHALL BE WIRED PER N.E.C., C.E.C., OR LOCAL ELECTRIC CODES

! DANGER: RISK OF ELECTRICAL SHOCK. DO NOT INSTALL OR USE THIS DEVICE IN SWIMMING AREAS. THIS PUMP HAS NOT BEEN INVESTIGATED FOR USE IN SWIMMING AREAS.

! DANGER: ROTATING PROPELLER COULD RESULT IN SERIOUS INJURY. TURN OFF POWER BEFORE SERVICING MACHINE.

! WARNING: RISK OF ELECTRIC SHOCK. CONNECT ONLY TO A PROPERLY GROUNDED CONNECTION. FAILURE TO CONNECT TO PROPER GROUND COULD RESULT IN PERSONAL INJURY.

E.L.C.I. INFORMATION

Equipment Leakage Current Interrupter is provided on Font'N-Aire Legacy fountains manufactured for use in the United States. Canadian Electric Codes require protection at the service entrance.

The ELCI used on USA Font'N-Aire Legacy 115-volt equipment has a nominal trip level of 10 mA. The E. L.C.I. is an Equipment Leakage Circuit Interrupter device only and not a circuit breaker nor should it be used as an on/of switch. .

Selecting the correct gauge and length of power supply wire is mandatory to avoid any equipment malfunctions due to voltage loss on to small of a gauge of wire. CONNECT PER N.E.C., C.E.C., OR LOCAL ELECTRIC CODES. Each unit is to be operated on individual circuits. Allow no more than 10 feet of exposed power cord between the power source and the fountain E. L. C. I.

VERIFICATION OF VOLTAGE

Verify that the voltage and phase of power available matches that of the equipment. It is recommended that you have a qualified electrical installer provide the appropriate receptacle for the fountain purchased. The single (1) phase, 115-volt Font'N-Aire Ready requires a 15 amp, 115-volt circuit. SUPPLY A DEDICATED CIRCUIT FOR EACH FOUNTAIN UNIT. It is strongly recommended to check and compare the amperage and performance characteristics with the information that is provided on the envelope containing this manual and record below.



LEGACY FOUNTAIN

Time Clock Mounting

The time clock used on the Font'N-Aire Legacy is installed between the ground fault circuit interrupter and the fountain.

Attach the time clock enclosure to a suitable support, i.e., post, or wall, adjacent to a power receptacle dedicated to the operation of the Legacy fountain. Mount the time clock with the receptacle downward and insert the Legacy fountain power cord plug into the time clock enclosure receptacle.

! CAUTION: If there is a probability of animals being present that could cause damage to occur to the Legacy fountain power cable that is supplied, it is suggested that at this time a protective flexible corrosion resistant conduit be implemented to minimize possible damage to the unit power cable.

STEP 2 After the mounting the controls and electric connection is complete, and the float is secured in the desired location it is then permitted to apply power and operate the Legacy fountain.

HOW TO SET THE TIME CLOCK

1. To set the current time, rotate the dial until the time lines up with the arrow.
2. To program the timer, push the tabs outward for the period of time you want the timer to be ON. Push the tabs in toward the center dial for the period of time you want the time to be OFF.
3. Set the switch to TIMER. Plug device into the time and turn the device ON. Plug timer into outlet.
4. Programmed setting repeats each day.
5. To override the timed settings, move the switch to ON.
- 6.

OPERATION

Each Font'N-Aire LEGACY is tested under operating conditions at the factory. The amperage and performance characteristics when the fountain was tested at the factory are listed on the envelope containing this operation and maintenance manual.

! CAUTION: DO NOT OPERATE THE FOUNTAIN WHILE OUT THE WATER.



FONT,N-AIRE LEGACY

REFERENCE OF INITIAL OPERATION

Save this manual for future reference by that of the owner or service facility.

Startup Date _____ Startup Voltage _____ Startup Amperage _____

Startup Height _____ Startup Width (If applicable) _____

MAINTENANCE

The Font’N-Aire LEGACY is virtually maintenance free. We recommend that you remove the unit from the water periodically to visually inspect and clean any debris build up on the motor and pump assembly and inspect the impeller for wear.

Prior to performing any service, turn the power off. Be certain that the power will not come back on.

1. Check the impeller for nicks, wear or broken blades.
2. Check the impeller for debris.
3. Check the power cable for cuts or abrasions in the jacketing

The motor is identified as the silver cylindrical device attached to and below the motor mount. The motor is water-lubricated and water-cooled. There is no circulation of water through the motor. It is sealed. **NO MAINTENANCE IS REQUIRED.** There are no serviceable parts. **DO NOT TAMPER WITH MOTOR OR DISASSEMBLE THE MOTOR. SUCH TAMPERING WILL BE EVIDENT AND WILL VOID THE WARRANTY.**

Check all fasteners for proper tension. Pump body fasteners are to be tightened no more than 50 in/lbs. in a random pattern. **! Caution:** Do not over tighten as breakage may occur. The 5/16” motor mount nuts should be tightened to 85 in/lbs.



LEGACY

TROUBLE SHOOTING PROCEDURE

Due to the extremely simple design of the Font' N-Aire Legacy fountain and minimal maintenance required there is consequently a limited amount of trouble shooting to be sought. A volt ohmmeter is required to complete these checks.

! DANGER: Electric shock hazard. **Disconnect and lockout the electrical power before servicing.**

If the fountain does not start:

- (1) Check for the correct voltage by using a voltmeter and verify that the voltage is within **10%** of the nameplate rating. If the voltage is incorrect contact a licensed electrician or your power company.
- (2) If the correct voltage is present check for loose connections or a tripped circuit breaker. If the problem persists contact your electrician.
- (3) Check for loose connections.

If the fountain runs but the overloads trip:

- (4) Check for the correct voltage at the incoming line terminals. The voltage must be within **10%** of the nameplate voltage on the motor. Contact an electrician to correct the problem.
- (5) Within the motor there is an automatic reset overload protection device which is sensitive to an overload amperage in excess 12 amps and will cause the motor to stop operating if an overload is indicated. Find the cause of the overload such as debris around the propeller or motor shaft or even a worn bearing in the motor.
- (6) Check the power cable and motor lead for cuts or breaks using an ohmmeter. Never attempt to tape or splice a cable or motor lead.
- (7) There is nothing to repair on or in the Franklin motor. If found to be defective; replace the motor.



**INSULATION & WINDING
RESISTANCE VALUES**

CONDITION OF MOTOR AND LEADS	OHM VALUE	MEGOHM VALUE
A used motor which can be reinstalled.	10,000,000 (or more)	10.0
MOTOR IN WATER. Ohm readings are for drop cable plus motor.		
A motor in the water in reasonably good condition	500,000-2,000,000	0.5-2.0
A motor which may have been damaged by lightning or with damaged leads. Do not pull aerator this reason.	20,000-500,000	0.02-0.5
A motor which definitely has been damaged or with a damaged cable. The aerator should be pulled and repairs made to the cable or the motor replaced. The motor will not fail for this reason alone, but it will probably not operate for long.	10,000-20,000	0.01-0.02
A motor which has failed or with completely destroyed cable insulation. The aerator must be pulled and the cable repaired or the motor replaced.	less than 10,000	0.0-0.1

Insulation resistance does not vary with rating. All motors of all HP, voltage, and phase rating have the same value of insulation resistance.



LEGACY

NOZZLE INSTALLATION AND REMOVAL

The nozzle plenum torque values should be 50 in/lbs. If the spray pattern changes from the original configuration, inspect for and remove any foreign matter that may be present within the pump and nozzle areas. The primary location to look for these obstructions or foreign materials would be within the nozzle.

CENTRIFUGAL PUMP NOZZLES

Font'N-Aire Legacy centrifugal pump units are provided with removable P V C nozzles. Font'N-Aire Legacy provides this convenience for ease of cleaning and exchange or replacement.

Nozzle's "A & B" are held into the water plenum by two 10-24 machine screws.

STORAGE

Place the unit in an upright position. Do not expose to temperatures below -20°F and avoid exposure to temperatures over 120°F.

It is recommended that the fountain equipment be removed in freezing conditions. If the Legacy fountain is left in the water, do not allow it to freeze in place. Damage to the equipment could result.



FONT'N-AIRE LEGACY

CERTIFICATE OF LIMITED WARRANTY

2007

1. Your Legal Rights Under This Warranty

This warranty is the only express warranty that Air-O-Lator makes for your Air-O-Lator product. This warranty gives you specific legal rights.

This warranty is only for products sold for use in the USA.

THERE ARE NOT WARRANTIES WHICH EXTEND BEYOND THE DESCRIPTION ON THE FACE HEREOF.

This warranty will be governed by the laws of the State of Missouri, USA.

2. What's Covered

2.1 Basic Warranty

Air-O-Lator warrants to the original purchaser that the equipment delivered by it will be of the kind and quality described in the order and will be free of defects in **workmanship, material or factory preparation** when operated under normal use and services.

A. What's Covered at No Cost to You

The Basic warranty covers the cost of all parts needed to repair any defective item on your Air-O-Lator product-that is, defective in material, workmanship or factory preparation.

Warranty repairs or adjustments including all parts and labor connected with them will be made at Air-O-Lator Corporation or an AUTHORIZED repair facility.

B. Products Covered

All FONT'N-AIRE **LEGACY** fountains using Franklin Electric 4" motor.

C. When It Begins

The Basic Warranty begins on either of the following dates, whichever is earlier:

- The date you take delivery of the Air-O-Lator product or
- The date when the product was first put into service up to **18 months** from the date of manufacture.

D. When It Ends

The Basic Warranty lasts for **12 months** for the Font'N-Aire LEGACY.

Exceptions

Exceptions to the **12 month** warranty are: equipment used in severe environments, which are not warranted. I.e., wastewater applications or where high concentrations of corrosive or abrasive material are present.

E. Registration and Operation Requirements

The Basic Warranty covers your Air-O-Lator product only if:

- It was built for sale in the U.S.
- It's registered in the U.S.
- It's used in the U.S. and
- It's operated and maintained in the manner described in your Owner's Manual.

3. What's Not Covered

3.1 Modifications Not Covered

A. Some Modifications Don't Void this Warranty but Aren't Covered

Certain changes that you might make to your product do not, by themselves, void this warranty. Examples of some of these changes are:

- Installing non-Air-O-Lator supplied parts, components, or equipment (such as a non-Air-O-Lator supplied Franklin Electric motor, stainless steel fasteners, or fountain nozzles).

But this warranty does not cover any part that Air-O-Lator did not supply. Nor does this warranty cover the cost of any repairs or adjustments that might be caused or needed because of the installation or use of non-Air-O-Lator parts, components, equipment, or materials.

Examples of the types of alterations not covered are:

- Installing accessories – except for genuine Air-O-Lator accessories approved for installation – such as lighting, propeller guards, rock covers, or motors.
- Labor to install or remove any Air-O-Lator product.

B. Modifications That Will Void Your Warranty

Disconnecting, tampering with, or altering the electric controls will void your warranty, unless you or your repairing technician follows Air-O-Lator's requirements for repairing or replacing the controls.

Removing and operating Air-O-Lator equipment without Air-O-Lator approved electrical controls will also void this warranty. Using any electric cable, connectors or splices not provided or authorized by Air-O-Lator will also void this warranty.

3.2 Environmental Factors Not Covered

This warranty does not cover damage caused by environmental factors such as, chemicals, and salt. Nor does your warranty cover damage caused by **windstorms, hailstorms, tornadoes, lightning, power surges, brownouts, floods, earthquakes debris and animals.**

3.3 Maintenance Costs Not Covered

This warranty does not cover the cost of repairing damage caused by poor or improper maintenance. This warranty does not cover the costs of your equipment's normal or scheduled maintenance I.e. annual propeller/impeller replacement, cleaning etc.

3.4 Incidental and Consequential Damages Not Covered

This warranty does not cover any incidental or consequential damages connected with Air-O-Lator products' failure, either while under warranty or afterward. Examples of such damages include:

- Lost time, Inconvenience; The loss of the use of equipment; The loss of personal or commercial property; The loss of revenue; and delay.

3.5 Certain Kinds of Corrosion Not Covered

This warranty does not cover the following:

- Corrosion caused by accident, damage, abuse, or alteration;
- Surface corrosion caused by such things as, sand, salt, stones and barnacles.
- Corrosion caused by the extensive or abnormal exposure of caustic materials like chemicals, acids, and fertilizers.

3.6 Freight:

Warranty shipping charges are to be pre-paid by the owner.

Warranty shipping charges are the responsibility of the owner.

4. How To Get Warranty Service

4.1 Where to Take Your Air-O-Lator Product

Air-O-Lator authorizes you to return your Air-O-Lator products to the factory upon notification.

You may contact: Air-O-Lator Corporation: 8100-04 Paseo, Kansas City, MO 64131, 1-800-821-3177. <http://airolator.com>

CUSTOMER REGISTRATION COPY

Owner Name_____	Model _____
Date Purchased_____	Serial No._____
Owner Address_____	Dealer Name_____
City_____	Address_____
State_____ Zip_____	City_____ State_____ Zip Code_____

NOTE: This information should be retained for your file.

**AIR-O-LATOR CORPORATION, 8100-04 PASEO, KANSAS CITY, MO 64131
1-800-821-3177 <http://airolator.com>**



8100-04 Paseo, Kansas City, Missouri 64131
800-821-3177

MAIL IN FORM

WARRANTY REGISTRATION

Font' N-Aire

Legacy

Purchase Date Mo. _____ Day _____ Year _____

Model No. _____ Serial No. _____

Owner Name _____ Dealer Name _____

Owner Address _____ Dealer Address _____

City _____ City _____

State _____ ZIP Code _____ State _____ ZIP Code _____



AIR-O-LATOR CORPORATION REPAIR RETURN FORM

To avoid delays in the repair of equipment in question, it is best to call the factory at 1-800-821-3177 to determine what portion or portions of the equipment in question should be returned. The fountain or aerator unit itself (that portion that sets down into the hole in the floatation) is to be returned completely assembled. **DO NOT DISASSEMBLE ANY PORTION WITHOUT PRIOR AUTHORIZATION!**

Shipping costs to and from the factory are the responsibility of the shipper as is the packaging. Air-O-Lator encourages the use of the original shipping container that is UPS approved for this equipment to minimize the possibility of shipping damage. Additional charges will apply if original packaging is not retained.

If the original packaging is not retained and used by the customer, Air-O-Lator will supply replacement packaging (at a nominal charge) upon return of the equipment to the shipper (call for current pricing).

Upon the inspection of returned equipment, whether in warranty or not, contact by Air-O-Lator to proceed with repair will be made to the owner or agent with an explanation of the repairs and charges if any. **NO REPAIRS WILL BE MADE UNLESS AUTHORIZED BY THE OWNER OR AGENT.** If Air-O-Lator is unable to contact the owner/agent within 30 days after receipt of the equipment for repair, a "signature required" notice will be forwarded to the owner or agent stating that disposal of the equipment will be made 30 days from the date of the notice.

Name _____

Address _____

Phone _____ FAX _____ E-Mail _____

E-mail _____ Equipment Serial # _____

Comments: _____

FONT'N-AIRE LEGACY CENTRIFUGAL PUMP PARTS LIST

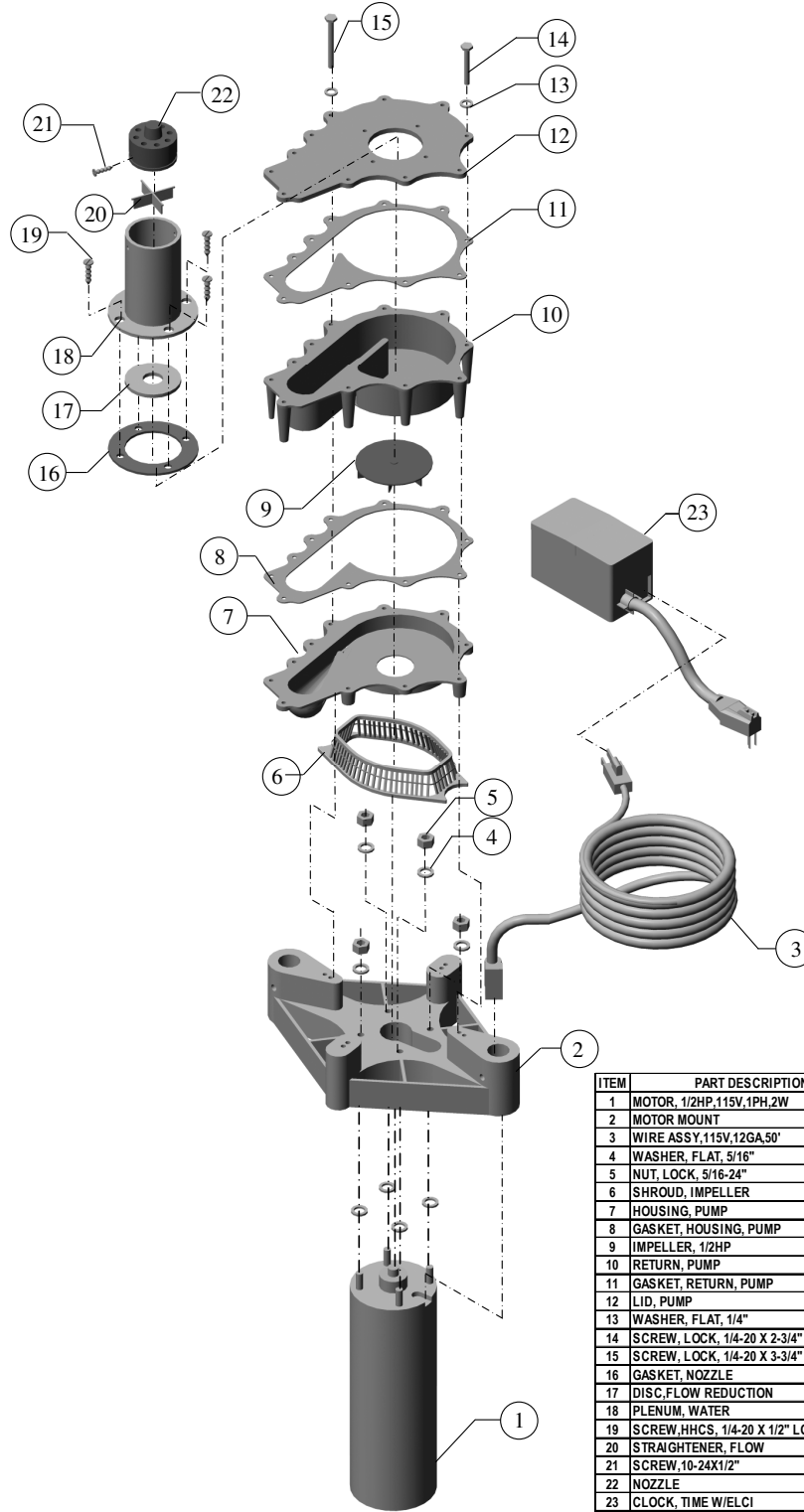

ITEM	PART DESCRIPTION	QTY	PART NUMBER
1	MOTOR, 1/2HP, 115V, 1PH, 2W	1	4924450401
2	MOTOR MOUNT	1	04MMF-AM
3	WIRE ASSY, 115V, 12GA, 50'	1	90W211550123
4	WASHER, FLAT, 5/16"	4	18079025
5	NUT, LOCK, 5/16-24"	4	18078500
6	SHROUD, IMPELLER	1	70PGFNACP
7	HOUSING, PUMP	1	64PH-PIMG
8	GASKET, HOUSING, PUMP	1	64PHG2
9	IMPELLER, 1/2HP	1	70CPIM12
10	RETURN, PUMP	1	64PR-PIMG
11	GASKET, RETURN, PUMP	1	64PRG2
12	LID, PUMP	1	64PRL-PIMG
13	WASHER, FLAT, 1/4"	11	18079020
14	SCREW, LOCK, 1/4-20 X 2-3/4"	7	18101025275LL
15	SCREW, LOCK, 1/4-20 X 3-3/4"	4	18101025375LL
16	GASKET, NOZZLE	2	64GFN
17	DISC, FLOW REDUCTION	1	64FRD
18	PLENUM, WATER	1	64WPCCP
19	SCREW, HHCS, 1/4-20 X 1/2" LOCK	4	1810102550LL
20	STRAIGHTENER, FLOW	1	64FSCP
21	SCREW, 10-24X1/2"	1	18032200
22	NOZZLE	1	90NALGSET
23	CLOCK, TIME W/ELCI	1	90TC115G

1/1/07

FONT'N-AIRE LEGACY
SUB-ASSEMBLIES PARTS LIST

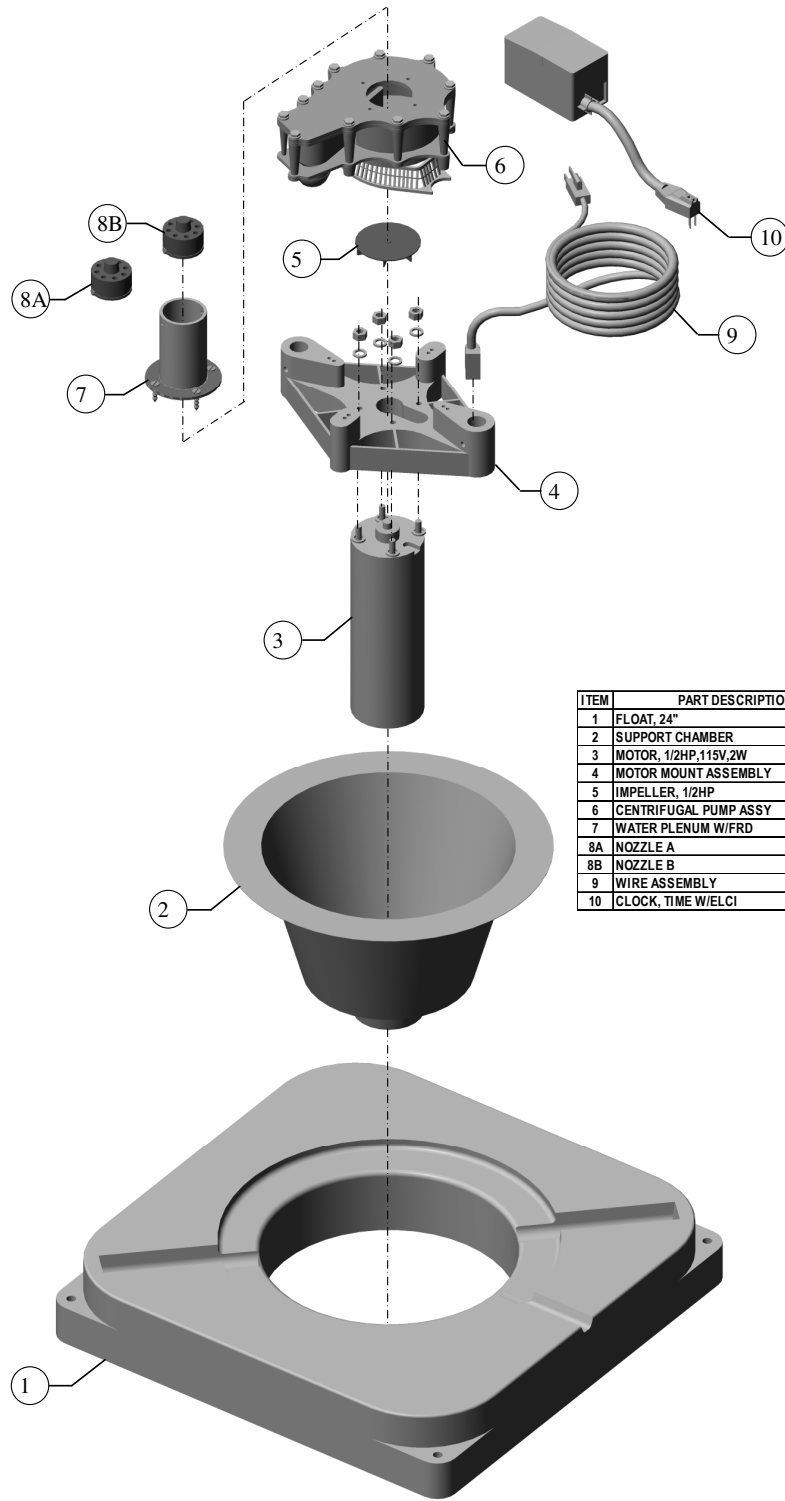

ITEM	PART DESCRIPTION	QTY	PART NUMBER
1	FLOAT, 24"	1	22FA24
2	SUPPORT CHAMBER	1	24FSC
3	MOTOR, 1/2HP,115V,2W	1	4924450401
4	MOTOR MOUNT ASSEMBLY	1	90MMLGIM
5	IMPELLER, 1/2HP	1	70CPIM12
6	CENTRIFUGAL PUMP ASSY	1	90CPA
7	WATER PLENUM W/FRD	1	90WPAFRD
8A	NOZZLE A	1	90NALGA
8B	NOZZLE B	1	90NALGB
9	WIRE ASSEMBLY	1	90W211550123
10	CLOCK, TIME W/ELCI	1	90TC115G

01/01/07