



# AQUARIAN<sup>®</sup>

## QUANTUM



MECHANICAL FLOATING AERATORS 5 HP - 20 HP



8100-04 Paseo, Kansas City, Missouri 64131

**INSTALLATION  
OPERATION  
AND  
MAINTENANCE  
OF THE  
AQUARIAN® QUANTUM®  
FLOATING AERATOR**

**DO NOT DESTROY!**

This manual is designed for use in the installation, operation and maintenance of the Aquarian® Quantum® aerator; Store this document in an easily accessible and dry location.

The following information is provided to alert persons to potential personal hazards inherent with electrical/mechanical products.

**! DANGER:** Indicates an eminently hazardous situation which, if not avoided, will result in death or serious injury.

**! WARNING:** Indicates a potentially hazardous situation which, if not avoided, could result in death or serious injury.

**! CAUTION:** Indicates a potentially hazardous situation which, if not avoided, may result in minor or moderate injury.

## **SAFETY DATA INFORMATION SHEET**

**! DANGER:** RISK OF ELECTRIC SHOCK. DO NOT INSTALL THIS EQUIPMENT IN SWIMMING AREAS. THIS EQUIPMENT HAS NOT BEEN INVESTIGATED FOR USE IN SWIMMING AREAS.

**! WARNING:** DISCONNECT AND LOCK OUT ELECTRICAL POWER BEFORE ANY SERVICE IS PERFORMED ON THIS DEVICE.

**! WARNING:** THE CONTROL PANEL AND UNIT MUST BE GROUNDED. FAILURE TO CONNECT TO A PROPER GROUND COULD RESULT IN PERSONAL INJURY OR DEATH.

**! WARNING:** BEFORE ATTEMPTING TO INSTALL, SERVICE OR MAINTAIN THE UNIT AND / OR FLOTATION IN ANY BODY OF WATER; A COAST GUARD APPROVED (PFD, TYPE III OR HIGHER) PERSONAL FLOTATION DEVICE MUST BE WORN.

**! WARNING:** THE FLOTATION PROVIDED FOR THIS EQUIPMENT, HAS NOT BEEN INVESTIGATED PERSONAL FLOTATION DEVICE.

**! WARNING:** ATTEMPTING TO INSTALL OR SERVICE EQUIPMENT FROM AN UNSTABLE WORK PLATFORM COULD RESULT IN DEATH OR INJURY.

**! WARNING:** POSSIBLE CUTTING HAZARD. ROTATING PROPELLER COULD RESULT IN SERIOUS INJURY. TURN OFF POWER AND LOCK OUT BEFORE INSTALLATION OR SERVICING.

**! CAUTION:** DO NOT OPERATE THIS EQUIPMENT OUT OF THE WATER. (EXCEPTION:) IT IS PERMISSABLE TO BUMP RUN 3-PHASE EQUIPMENT OUT OF THE WATER TO VERIFY COUNTER CLOCKWISE MOTOR ROTATION WITH A RAPID ON/OFF ACTION.

**! CAUTION:** INSTALLATION OR SERVICE WORK MUST BE PERFORMED FROM A STABLE WORK PLATFORM TO AVOID THE POSSIBILITY OF CAPSIZING.

## POWER CABLE SELECTION AND THE ATTACHMENT TO THE JUNCTION BOX

**! DANGER:** ELECTRIC SHOCK HAZARD. DISCONNECT ELECTRIC POWER AND LOCK-OUT BEFORE SERVICING ELECTRIC CONTROLS OR AERATOR.

POWER CABLE (waters edge to aerator).

Flexible water and U. V. resistant power cable is to be used for connection between the waters edge and the Aquarian® Quantum® aerator. 300 VOLT SJTOW cable for 230 volt motors 600 VOLT SEOW cable for 460 volt motors is acceptable by the N.E.C. (National Electric Code) for wet locations and is factory approved for use on Air-O-Lator® Aquarian® Quantum® aerators.

**REFER TO THE CABLE SELECTION GUIDE (page 4).**

During the course of cable selection you must consider the entire power supply run from the **service entrance** to the **aerator** to avoid concerns of voltage drop.

If the factory provided the power cable (waters edge to the aerator) it is important to select the correct size (gauge) cable from the service entrance to the waters edge based on the total percentage of power supply run service entrance to aerator overall based on the National Electric Code (N.E.C.) or local codes.

(1) POWER CABLE ATTACHMENT (shore to aerator).

(1a) Remove the junction box cover screws, the box cover, and the box cover gasket.

(1b) Next remove the strain-relief gland nut and the rubber bushing that is part of the strain relief connector. Use caution to **not** misplace the screws, the box cover, the box cover gasket, gland nut or the rubber bushing.

(1c) Slide the strain-relief gland nut onto the cable; then slide the rubber bushing onto the cable. Leave about 8 inches of cable protruding past the gland nut.

(1d) Strip approximately 6 inches of the outer jacket from the cable and remove the filler/separator material located between the cable leads.

Then insert the cable into the hub of the junction box strain-relief connector and tighten the gland nut by hand being certain the cable does not slide in or out of the strain-relief.

**NOTE:** THE JUNCTION BOX IS NOT MEANT TO BE WATERTIGHT. DO NOT ATTEMPT TO SEAL OR FILL THE JUNCTION BOX BY ANY MEANS.

THE SPLICE CONNECTION WITHIN THE JUNCTION BOX IS MADE WATER-TIGHT BY IMPLEMENTING **ONE TIME USE** UL LISTED PRESSURE-TYPE DIELECTRIC SILICONE GREASE FILLED WIRE CONNECTORS.

**Single Phase Cable Selection Guide**  
(Service Entrance to Aerator Maximum Length in Feet)

HORSEPOWER	VOLTAGE	12 AWG Feet	10 AWG Feet	8 AWG Feet	6 AWG Feet	4 AWG Feet
5	230	NA	Max Lgth 150'	Max Lgth. 250'	Max Lgth. 450'	Max Lgth. 700'
7.5	230	NA	NA	Max Lgth. 200'	Max Lgth.300'	Max Lgth. 450'
10	230	NA	NA	Max Lgth. 150'	Max Lgth. 250'	Max Lgth. 350'
15	230	NA	NA	NA	Max Lgth. 150'	Max Lgth. 250'

**230-Volt Three Phase Cable Selection Guide**  
(Service Entrance to Aerator Maximum Length in Feet)

HORSEPOWER	VOLTAGE	12 AWG Feet	10 AWG Feet	8 AWG Feet	6 AWG Feet	4 AWG Feet
5	230	Max Lgth. 230	Max Lgth. 370	Max Lgth. 590	Max Lgth. 920	Max Lgth. 1430
7.5	230	Max Lgth. 160	Max Lgth. 260	Max Lgth. 420	Max Lgth. 650	Max Lgth. 1020
10	230	N/A	Max Lgth. 190	Max Lgth. 310	Max Lgth. 490	Max Lgth. 760
15	230	N/A	N/A	Max. Lgth. 210	Max Lgth. 330	Max Lgth. 520
20	230	N/A	N/A	N/A	Max Lgth. 250	Max Lgth. 400

**460-Volt Three Phase Cable Selection Guide**  
(Service Entrance to Aerator Maximum Length in Feet)

HORSEPOWER	VOLTAGE	12 AWG Feet	10 AWG Feet	8 AWG Feet	6 AWG Feet	4 AWG Feet
5	460	Max Lgth. 950	Max Lgth. 1500	Max Lgth. 2360	Max Lgth. 3700	Max Lgth. 5750
7.5	460	Max Lgth. 680	Max Lgth. 1070	Max Lgth. 1690	Max Lgth. 2640	Max Lgth. 4100
10	460	Max Lgth. 500	Max Lgth. 790	Max Lgth. 1250	Max Lgth. 1690	Max Lgth. 3050
15	460	Max Lgth. 340	Max Lgth. 540	Max Lgth. 850	Max Lgth. 1340	Max Lgth. 2040
20	460	N/A	Max Lgth. 410	Max Lgth. 640	Max Lgth. 1030	Max Lgth. 1610

Note: Lengths indicated on the above charts meet or exceed the National Electric Code (NEC) ampacity for either individual conductors or jacketed 60°C.

## JUNCTION BOX ELECTRICAL WIRING

### FLEXIBLE CABLE TO THE MOTOR LEAD

#### Water-tight Splicing

- (1) Air-O-Lator has supplied the appropriate size wire connectors to make the splice between the Aquarian® Quantum® motor lead and the cable to the waters edge. Air-O-Lator may have already connected the power supply wire (aerator to waters edge) depending on the length power cable ordered. If the wire is not factory connected; the cable will have to have the outer jacket removed from 6 to 8 inches. The individual leads will have to have approximately ½ inch of insulator from each individual lead.
- (2) Using the factory supplied dielectric silicone grease filled wire connectors; connect the motor lead wires to the power cable leads. There is no need to twist the leads together. Just place the leads side by side insert and tighten as you would standard wire connectors. Be certain no small strands of the cable leads are protruding past the connectors. This connection if properly completed will provide a watertight connection. See drawing #2.

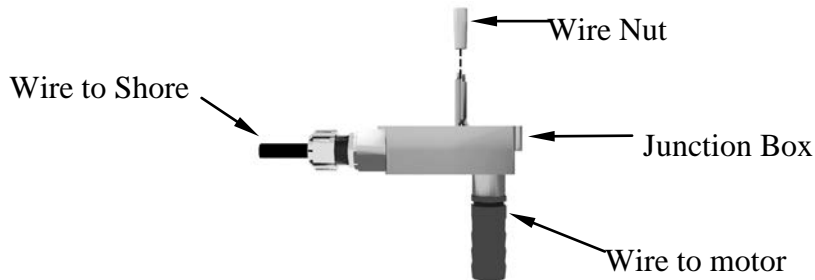

- (3) Insert the spliced leads into the junction box in a manner to minimize strain on the splice connection and reinstall the gasket and cover. See drawing #3.

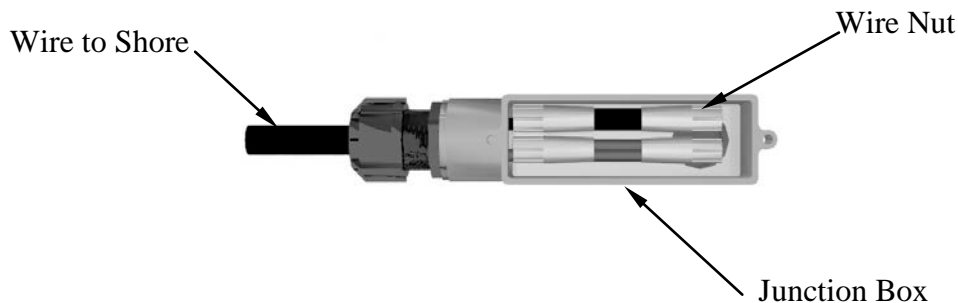

## **THREE PHASE CONTROL CONNECTIONS**

**! Danger:** Electric shock hazard. Disconnect electrical power before servicing panel or machine.

If the Air-O-Lator supplied I.E.C. motor protection device is used with the Quantum aerator, electric motor control sizing has been taken into consideration. All that is necessary is to mount the control in the desired location. Be certain that the power is off and locked out and enter the control with appropriate gauge service entrance wire, supply the proper voltage and make the necessary connections.

Enter the motor protection device (commonly through the base) and connect the unit cable to the appropriate contactor terminals if not already completed at the factory on the control relay.

**WIRE PER THE NATIONAL ELECTRIC CODE AND OR LOCAL CODES.**

While the aerator is running input voltage is to be maintained within + or – 10% of motor name plate voltage.

### **CORRECT MOTOR ROTATION (Three-phase equipment)**

#### **NOTICE! NOTICE! NOTICE!**

THE PROPELLER IS ATTACHED TO THE MOTOR BY MEANS OF AN INVOLUTE SPLINE IN THE BORE OF THE PROPELLOR AND SIMPLY IS SLID DOWN ONTO THE INVOLUTE SPLINE OF THE MOTOR SHAFT. THRUST HOLDS THE PROPELLER FIRMLY TO THE MOTOR SHAFT.

**! WARNING** Rotating propeller could result in serious injury. Turn off machine before servicing.

BEFORE INSTALLING THE AERATOR; APPLY POWER TO THE AERATOR AND “BUMP RUN” THE AERATOR ON THE SHORE TO VERIFY THAT COUNTER-CLOCKWISE ROTATION OF THE PROPELLER IS EVIDENT.

TO CORRECT THE MOTOR ROTATION YOU SIMPLY SWAP ANY TWO POWER LEAD POSITIONS.

CORRECT SHAFT ROTATION IS CRITICAL OTHER WISE THE PROPELLOR WILL COME OFF OF THE SHAFT OF THE MOTOR.

### Franklin Electric Submersible Single Phase Motor Specifications (60 Hz)

October, 2004

Motor				Maximum		Line to Line		Circuit Breaker	Fuse
							S.F.	Amp Size	Amp Size
Model Number	H.P.	Volts	S. F.	S.F.Amps	Watts	Resistance	Power Factor %	Standard	Time Delay
226110	5	230	1.15	Y23.0	5700	.55-.68 Motor	98.0 %	70	30
				B18.2		1.3-1.6 Start			
				R8.0					
226111	7.5	230	1.15	Y42.1	8800	.36-.50 Motor	91.0%	100	45
				B40.5		.92-1.2 Start			
				R5.4					
226112	10	230	1.15	Y44.0	11300	.27-.33 Motor	95.8%	150	60
				B39.5		.80-.99 Start			
				R9.3					
226113	15	230	1.15	Y62.0	16200		97.3 %	200	80
				B62.5		.17-22 Motor			
				R16.9		.68-.93 Start			

### Franklin Electric Submersible Three Phase Motor Specifications (60 Hz)

October, 2004

Motor				Maximum		Line to line		Circuit Breaker	Fuse
							S.F.	Amp size	Amp size
Model Number	H.P.	Volts	S.F.	S.F.Amps	Watts	Resistance	Power Factor %	Standard	Time Delay
236600	5	230	1.15	16.6	5400	.88-1.09	82.0%	45	20
236610	5	460	1.15	8.3	5400	3.53-4.37	82.0%	25	10
236601	7.5	230	1.15	24.6	8000	.57-.71	83.0%	70	30
236611	7.5	460	1.15	12.3	8000	2.17-2.68	83.0%	30	15
236602	10	230	1.15	32.2	10800	.44-.55	85.5%	80	35
236612	10	460	1.15	16.1	10800	1.76-2.17	85.5%	40	20
236603	15	230	1.15	41.6	13700	.27-.33	84.9%	125	60
236613	15	460	1.15	20.8	13700	1.07-1.32	84.9%	60	30
236604	20	230	1.15	60.6	20900	.20-.25	86.8%	175	70
263614	20	460	1.15	30.3	20900	.76-.94	86.8%	80	35



**AQUARIAN® QUANTUM®  
AERATOR  
INSTALLATION INSTRUCTION**

**MAKE SURE THE MOTOR ROTATION IS COUNTER CLOCKWISE**

- (1) Cut the mooring cable from the reel or coil provided (if ordered) to the required length.
- (2) Attach the mooring cables to the flotation using the “clips” and “thimbles” provided (if ordered) to the stainless “eyes” factory installed to the flotation platform corners.
- (3) Wrap the stainless steel cable around the “thimble” (the tear drop shaped piece) and attach the “clip” (the clamp device with the u-bolt and nuts) as close to the “thimble” as possible and tighten. If a two “clip” design is required proceed with and complete the installation of the additional “clip” and tighten.
- (4) Make the same connection to the remaining corner. In the case of a four (4) corner application complete those connections at the same time. See diagram below.

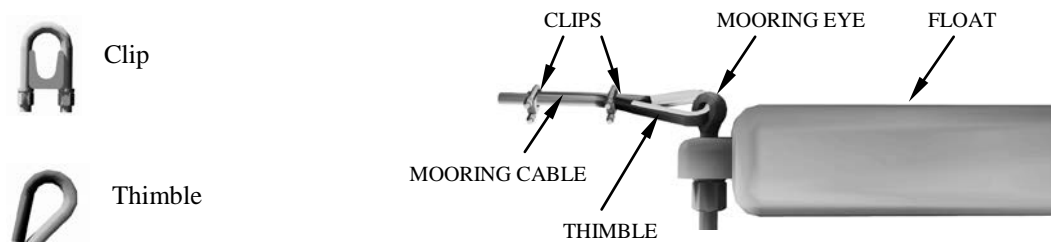

- (5) You may now install the Quantum unit into the flotation. Be certain that the motor is not allowed to rest in any muck or mire that is sometimes prevalent particularly in existing lagoons or at the water’s edge. The Quantum aerator is modular in design and sets directly on the flotation platform. The unit requires no attaching hardware. Downward thrust developed by the unit holds the aerator in position. This design concept allows for easy removal of the aerator for service. See diagram below.

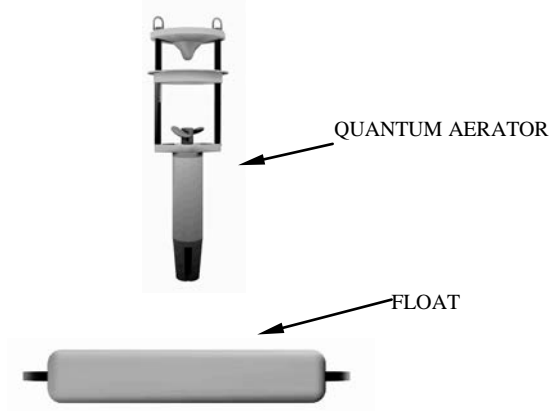

- (6) Attach the opposite end of the mooring cable to the mooring method of choice (usually anchors made of concrete building blocks or 4 per corner. Anchors can be made of 1cft solid pour concrete in a block form with poured in place mooring eyes.

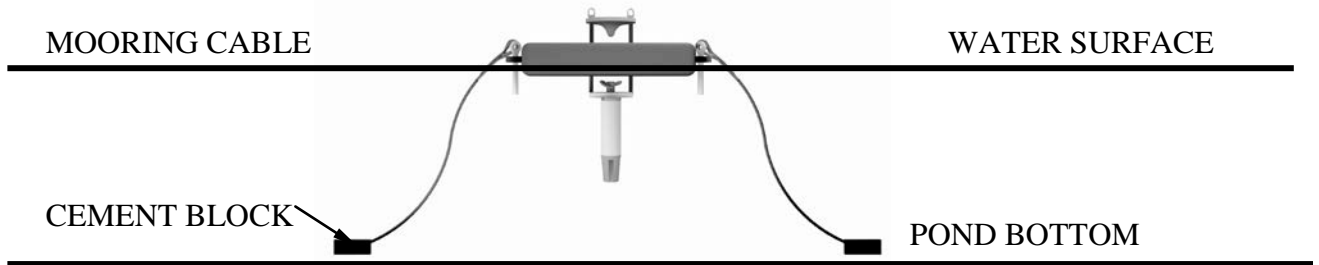

- (7) An alternate method to secure the aerators is to connect the cable to mooring posts secured in concrete on the berm or shore.

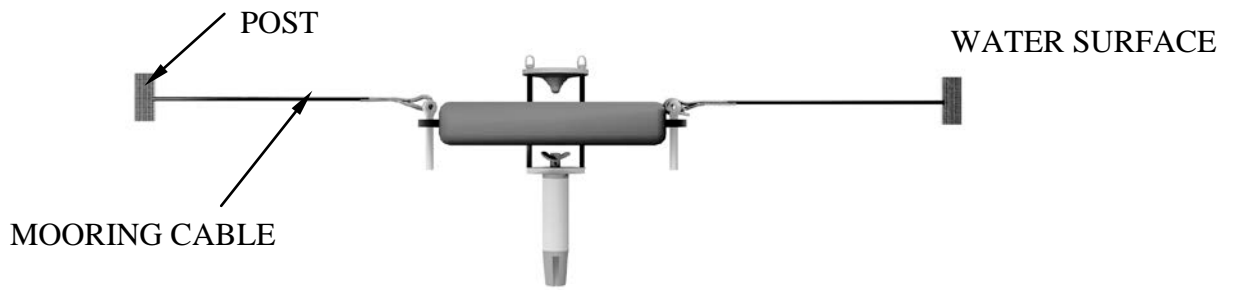

**The flotation, aerator and power cord installation is now complete.**

Now that the Quantum® aerator has been installed and after being certain that no personal injury to your own person or to others; you may apply power and verify that the unit is operating at the correct **voltage and amperage** as tested, indicated and is provided on the envelope of this **Installation, Operation & Maintenance Manual**

## THREE PHASE CURRENT UNBALANCE

A full three phase supply is recommended for all three phase motors, consisting of three individual transformers or one three phase transformer.

So called “open” delta or wye connections using only two transformers can be used, but are more likely to have problems, such as poor performance, overload tripping or early motor failure due to current unbalance.

Contact a licensed electrician for the confirmation of transformer selection sizing and installation per the National Electric Code or local codes.

### Checking and correcting current unbalance:

**! Danger:** Electric shock hazard. Disconnect power before servicing panel or machine.

(1) With the aerator operating, check the current (amperage) of each of the three power leads going to the aerator at the motor protector indicated as T-1, T-2, T-3 and determine the amount of unbalance; if any; in percent as explained below.

(2) If the current unbalance is within 2% or less, there is no need to correct the unbalance indicated.

If the current unbalance is greater than 2%, (roll) the motor leads at the point where the power leads connect to the motor starter; indicated as T-1, T-2, and T-3. Rolling the leads is best described as moving the **Red**, **Black**, **Yellow** or **White**, wires going to the aerator motor protection device. As an example: **R is moved from** T-1 to T-2, **B is moved from** T-2, to T-3, **Y or W is moved from**, T-3 to T-1. This can be done two (2) more times before you start all over again. You are looking for the smallest current unbalance as you can achieve.

(4) To calculate the percent of current unbalance:

(A) Add the three line current (amp) values together.

(B) **Divide** the total by three (the number of current readings taken) to yield the average current (either high or low).

(C) Choose the amp value which is furthest from the average current (either high or low).

(D) Determine the difference between this amp value (furthest from average) and the average previously determined in (B) above.

(E) Divide the difference by the average. **Multiply** the result by 100 to determine the percent of unbalance.

(5) Current unbalance should not exceed 5% at service factor amperage (max amps). If the unbalanced condition cannot be corrected by (rolling) the leads, the source of the unbalance must be located and corrected. If, on the three possible lead hookups, the leg farthest from the average stays on the same power lead, the most probable cause is on the “power supply side” and you should contact the power company. If however the reading farthest from average moves with the same motor lead, the primary cause would be to suspect the “motor side”. In this instance consider a; damaged cable, poor splice connection or a faulty motor winding.

## **USER SUPPLIED MOTOR CONTROLS**

If user supplied controls are to be implemented there are certain **Minimum** standards to be met for proper operation and warranty consideration and were addressed in the original specification. However in review these items of consideration are to be as follows:

- (1) The use of IEC contactors and adjustable overload relays sized for the horsepower and voltage used automatically provide phase loss protection and is the preferred motor protection.
- (2) Ambient compensated quick trip NEMA contactors are the bare minimum for motor protection and may also be used.
- (3) Fusing must be of the appropriate rating and time delay in design.
- (4) Due to the amount of exposure to lightning storms; lightning protection is also required.

STRONGLY SUGGESTED, HOWEVER NOT REQUIRED ARE THE FOLLOWING:

- (A) Installation of time delay relays in the case of multiple units.
- (B) Installation of a phase-reversal protection device is also encouraged.
- (C) After a power outage; verify correct motor rotation as power companies may switch phases unintentionally.
- (D) Lightning protection is also desirable.

## MAINTENANCE

The Aquarian® Quantum® aerator Franklin Electric motors have hermetically sealed windings and are water cooled.

The bearings and motor shaft are water lubricated.

If you were to look inside a Franklin Electric motor you would find water. This is normal.

**Never** attempt to open the motor. Attempting to do so will be evident and will void the warranty.

There are no serviceable parts within the motor.

The motor is sealed by an extremely durable “silicon carbide” mechanical shaft seal and does not require any routine seal maintenance; or lubricating / cooling medium change.

Aquarian® Quantum® aerator maintenance consists of observing the operating characteristics of the aerator to see if the spray pattern has deviated from the original appearance. If this condition occurs it is recommended to turn the aerator off.

**!WARNING: Rotating propeller could result in serious injury. Turn off power before servicing machine.**

Lock out the power source to prevent accidental operation and inspect the unit for debris build-up around the propeller and or motor shaft and the subsequent removal of the debris.

**!DANGER: Electric shock hazard. Disconnect electrical power before servicing panel or machine.**

Every 6 months remove the unit from the water and eliminate any foreign matter that may be evident.

At the same time check the condition of the propeller. Have the balance and pitch checked and if found to be in question do not operate the aerator. An imbalanced condition will promote vibration, premature bearing failure and ultimate motor failure. Repair or replace the propeller promptly. Contact the factory 1-800-821-3177 and have at hand the serial number, voltage and horsepower to aid in providing the best service.

It is best to remove the unit from the impoundment to perform mechanical service on the Aquarian® Quantum®.

Remove the propeller by means of a gear puller or similar device.

Reinstall the propeller clean all mating surfaces (Motor shaft spline and propeller spline) and apply a small amount of silicone rubber sealant to each component and allow it to cure. The silicone rubber is used to hold the propeller in place during the re-installation of the aerator to minimize the chance of the propeller being dislodged and falling into the basin.

Check all fasteners for proper torque as prescribed below:

¼-20 Cable clips are to be tightened to 78 in-lbs/6-ftlbs.

5/16-18 cap screw are to be tightened to 138 in-lbs/11ft-lbs.

½-24 Motor bolt should be tightened to 45 ft-lbs.

¾-10 Drive structure strain rods should be tightened to 120ft-lbs.

## TROUBLE SHOOTING PROCEDURE

Due to the extremely simple design of the Aquarian® Quantum® aerator and minimal maintenance required there is consequently a limited amount of trouble shooting to be sought. A volt ohmmeter is required to complete these checks.

**! DANGER:** Electric shock hazard. Disconnect and lockout the electrical power before servicing panel or machine.

If the aerator does not start:

- (1) Check for the correct voltage by using a voltmeter and verify that the voltage is within 10% of the nameplate rating. If the voltage is incorrect contact a licensed electrician or your power company.
- (2) If the correct is present check for the correct size of fuses, loose connections or a tripped circuit breaker. Replace the fuses with the correct size and rating or reset the circuit breaker. If the problem persists contact your electrician.
- (3) In the case of single phase equipment check for loose connections or overload breakers of which there are two (located on the bottom of the control box) that may have tripped and push to reset.
- (4) Inspect the power cord and motor lead with an ohmmeter check for continuity. Check for cuts causing short circuits. Replace as necessary with a new motor lead or power cable. Use the correct gauge and type for the power cable that being SOW or SEOW.

If the aerator runs but the overloads trip:

- (5) Check for the correct voltage at the incoming line terminals. The voltage must be within 10% of the nameplate voltage. Contact the power company to correct the voltage.
- (6) Overloads are heat sensitive and can trip if a control box is exposed to an excessive amount of ambient heat. Shade or move the control box away from the heat source.
- (7) A possible condition although remote is that a control box has defective components or is defective. Possible causes are lightning or power surges. Repair or replace the defective components or the entire control box as required.
- (8) Check the power cable and motor lead for cuts or breaks using an ohmmeter. Never attempt to tape or splice a cable or motor lead.
- (9) The motor may be defective. There is nothing to repair in the motor. If found to be defective; replace the motor if required.

## INSULATION & WINDING RESISTANCE VALUES

CONDITION OF MOTOR AND LEADS	OHM VALUE	MEGOHM VALUE
A used motor which can be reinstalled.	10,000,000 ( or more)	10.0
MOTOR IN WATER. Ohm readings are for drop cable plus motor.		
A motor in the water in reasonably good condition	500,000-2,000,000	0.5-2.0
A motor which may have been damaged by lightning or with damaged leads. Do not pull aerator this reason.	20,000-500,000	0.02-0.5
A motor which definitely has been damaged or with a damaged cable. The aerator should be pulled and repairs made to the cable or the motor replaced. The motor will not fail for this reason alone, but it will probably not operate for long.	10,000-20,000	0.01-0.02
A motor which has failed or with completely destroyed cable insulation. The aerator must be pulled and the cable repaired or the motor replaced.	less than 10,000	0.0-0.1

Insulation resistance does not vary with rating. All motors of all HP, voltage, and phase rating have the same value of insulation resistance.

**End of Trouble Shooting**

# AQUARIAN “QUANTUM” AERATOR

## CERTIFICATE OF LIMITED WARRANTY

2008

### 1. Your Legal Rights Under This Warranty

This warranty is the only express warranty that Air-O-Lator makes for your Air-O-Lator product. This warranty gives you specific legal rights.

This warranty is only for products sold for use in the USA.

THERE ARE NO WARRANTIES, WHICH EXTEND BEYOND THE DESCRIPTION ON THE FACE HEREOF.

This warranty will be governed by the laws of the State of Missouri, USA.

### 2. What’s Covered

#### 2.1 Basic Warranty

Air-O-Lator warrants to the original purchaser that the equipment delivered by it will be of the kind and quality described in the order and will be free of defects in **workmanship, material or factory preparation** when operated under normal use and services.

#### A. What’s Covered at No Cost to You

The Basic Warranty covers the cost of all parts needed to repair any defective item on your Air-O-Lator product – that is, **defective in material, workmanship, or factory preparation**. Warranty repairs or adjustments – including all parts and labor connected with them – will be made at Air-O-Lator Corporation or an AUTHORIZED repair facility.

#### B. Products Covered

All **AQUARIAN “QUANTUM”** aerators using “6” Franklin Electric motors.

#### C. When It Begins

The Basic Warranty begins on either of the following dates, whichever is earlier:

- The date you **take delivery** of the Air-O-Lator product or
- The date when the product was first put into service for **12 months** up to **18 months** from the date of manufacture.

#### D. When It Ends

The Basic Warranty lasts for **12 months** for the Aquarian “Quantum” (12 months for equipment used in wastewater).

#### E. Exceptions

Exceptions to the **12 month** warranty are: equipment used in severe environments, which are warranted for 12 months, i.e., wastewater applications or where high concentrations of corrosive or abrasive material are present.

#### F. Registration and Operation Requirements

The Basic Warranty covers your Air-O-Lator product only if:

- It was built for sale in the U.S.
- It’s registered in the U.S.
- It’s used in the U.S. and
- It’s operated and maintained in the manner described in your Owner’s Manual.



### 3. What's Not Covered

#### 3.1 Modifications Not Covered

##### A. Some Modifications Don't Void this Warranty but Aren't Covered

Certain changes that you might make to your product do not, by themselves, void this warranty. Examples of some of these changes are:

- Installing non-Air-O-Lator supplied parts, components, or equipment (such as a non-Air-O-Lator supplied Franklin Electric motor, stainless steel fasteners, or fountain nozzles).

But this warranty does not cover any part that Air-O-Lator did not supply. Nor does this warranty cover the cost of any repairs or adjustments that might be caused or needed because of the installation or use of non-Air-O-Lator parts, components, equipment, or materials.

##### **Examples of the types of alterations not covered are:**

- Installing accessories – except for genuine Air-O-Lator accessories approved for installation – such as lighting, propeller guards, rock covers, or motors.
- Labor to install or remove any Air-O-Lator product.

##### B. Modifications That Will Void Your Warranty

Disconnecting, tampering with, or altering the electric control panels will void your warranty, unless you or your repairing technician follows Air-O-Lator's requirements for repairing or replacing the controls.

Removing and operating Air-O-Lator equipment without Air-O-Lator approved electrical controls will also void this warranty. Using any electric cable, connectors or splices not provided or authorized by Air-O-Lator will also void this warranty.

#### 3.2 Environmental Factors Not Covered

**This warranty does not cover** damage caused by environmental factors such as, chemicals, and salt. Nor does your warranty cover damage caused by **windstorms, hailstorms, tornadoes, lightning, power surges, brownouts, floods, earthquakes debris and animals.**

#### 3.3 Maintenance Costs Not Covered

This warranty does not cover the cost of repairing damage caused by poor or improper maintenance. This warranty does not cover the costs of your equipment's normal or scheduled maintenance i.e. annual propeller/impeller replacement, cleaning etc.

#### 3.4 Incidental and Consequential Damages Not Covered

This warranty does not cover any incidental or consequential damages connected with Air-O-Lator products' failure, either while under warranty or afterward. Examples of such damages include:

- Lost time, Inconvenience; The loss of the use of equipment; The loss of personal or commercial property; The loss of revenue; and Delay

#### 3.5 Certain Kinds of Corrosion Not Covered

This warranty does not cover the following:

- Corrosion caused by accident, damage, abuse, or alteration;
- Surface corrosion caused by such things as, sand, salt, stones and barnacles.
- Corrosion caused by the extensive or abnormal exposure of caustic materials like chemicals, acids, and fertilizers.

#### 3.6 Freight:

Warranty shipping charges are to be **pre-paid by the owner.**

Warranty shipping charges are the **responsibility of the owner.**

#### 4. How To Get Warranty Service

##### 4.1 Where to Take Your Air-O-Lator Product

Air-O-Lator authorizes you to return your Air-O-Lator products to the factory **upon notification**.

You may contact: **Air-O-Lator Corporation: 8100-04 Paseo, Kansas City, MO 64131, 1-800-821-3177.**  
**<http://airolator.com>**

## CUSTOMER REGISTRATION COPY

Owner Name _____	Model _____
Date Purchased _____	Serial No. _____
Owner Address _____	Dealer Name _____
City _____	Address _____
State _____ Zip _____	City _____ State _____ Zip Code _____

NOTE: This information should be retained for your file.

**AIR-O-LATOR CORPORATION, 8100-04 PASEO, KANSAS CITY, MO 64131**  
**1-800-821-3177 <http://airolator.com>**



8100-04 Paseo, Kansas City, Missouri 64131  
800-821-3177

## MAIL IN FORM

### WARRANTY REGISTRATION

Font' N-Aire

Aquarian

Ice-Away

Legacy \_\_\_\_\_

Residential \_\_\_\_\_

\_\_\_\_\_

Ready \_\_\_\_\_

Commercial \_\_\_\_\_

Platinum \_\_\_\_\_

Aquaculture \_\_\_\_\_

Gulf Stream \_\_\_\_\_

Quantum \_\_\_\_\_

Purchase Date Mo. \_\_\_\_\_ Day \_\_\_\_\_ Year \_\_\_\_\_

Model No. \_\_\_\_\_

Serial No. \_\_\_\_\_

Owner Name \_\_\_\_\_

Dealer Name \_\_\_\_\_

Owner Address \_\_\_\_\_

Dealer Address \_\_\_\_\_

City \_\_\_\_\_

City \_\_\_\_\_

State \_\_\_\_\_ ZIP Code \_\_\_\_\_

State \_\_\_\_\_ ZIP Code \_\_\_\_\_

# **AIR-O-LATOR CORPORATION**

## **REPAIR RETURN FORM**

To avoid delays in the repair of equipment in question, it is best to call the factory at 1-800-821-3177 to determine what portion or portions of the equipment in question should be returned.

The fountain or aerator unit itself (that portion that sets down into the hole in the floatation) is to be returned completely assembled. **DO NOT DISASSEMBLE ANY PORTION WITHOUT PRIOR AUTHORIZATION!**

Shipping costs to and from the factory are the responsibility of the shipper as is the packaging. Air-O-Lator encourages the use of the original shipping container that is UPS approved for this equipment to minimize the possibility of shipping damage. Additional charges will apply if original packaging is not retained.

If the original packaging is not retained and used by the customer, Air-O-Lator will supply replacement packaging (at a nominal charge) upon return of the equipment to the shipper (call for current pricing).

Upon the inspection of returned equipment, whether in warranty or not, contact by Air-O-Lator to proceed with repair will be made to the owner or agent with an explanation of the repairs and charges if any. **NO REPAIRS WILL BE MADE UNLESS AUTHORIZED BY THE OWNER OR AGENT.** If Air-O-Lator is unable to contact the owner/agent within 30 days after receipt of the equipment for repair, a "signature required" notice will be forwarded to the owner or agent stating that disposal of the equipment will be made 30 days from the date of the notice.

Name \_\_\_\_\_

Address \_\_\_\_\_

Phone \_\_\_\_\_ FAX \_\_\_\_\_ E-Mail \_\_\_\_\_

E-mail \_\_\_\_\_ Equipment Serial # \_\_\_\_\_

Comments: \_\_\_\_\_

\_\_\_\_\_

\_\_\_\_\_

QUANTUMAERATOR PARTS LIST, 5 H.P.

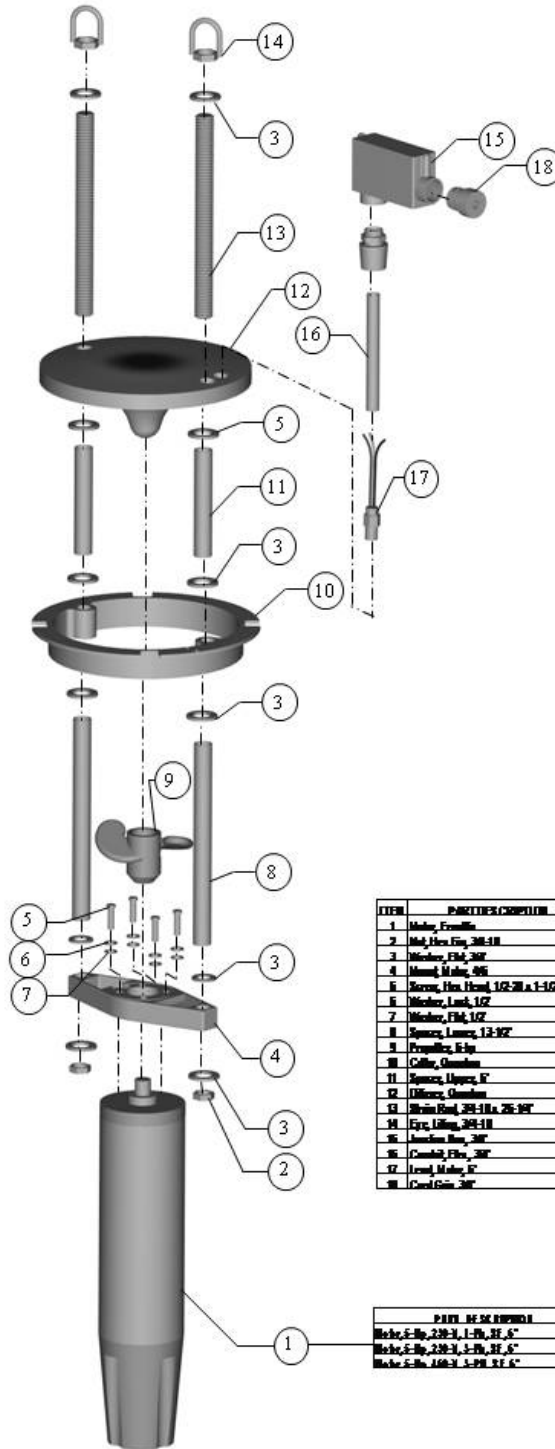

ITEM	PART DESCRIPTION	QTY	PART NUMBER
1	Motor, Frame	1	See Listing
2	Mid, Hex, Flg, 3/8-18	2	90226100
3	Washer, Flg, 3/8"	12	90226100
4	Washer, Flg, 3/8"	1	90226100
5	Washer, Flg, Head, 1/2-20 x 1-1/2"	4	90226100
6	Washer, Flg, 1/2"	4	90226100
7	Washer, Flg, 1/2"	4	90226100
8	Spacer, Lense, 1.2-1/2"	2	90226100
9	Flange, 5/8"	1	71952200
10	Collar, Gasket	1	90226100
11	Spacer, Upper, 1"	2	90226100
12	Diffuser, Gasket	1	90226100
13	Wiring Rod, 3/8-18 x 26-3/4"	2	90226100
14	Eye, Lid, 3/8-18	2	90226100
15	Anchor, Box, 3/8"	1	90226100
16	Cam, Flg, 3/8"	12	90226100
17	Lead, Mktg, 1"	1	90226100
18	Card, Gsk, 3/8"	1	See Listing

ITEM	PART DESCRIPTION	QTY	PART NUMBER
1	Motor, 5-Hp, 230-V, 1-Ph, 3F, 6"	1	90226100
2	Motor, 5-Hp, 230-V, 1-Ph, 3F, 6"	1	90226100
3	Motor, 5-Hp, 110-V, 1-Ph, 3F, 6"	1	90226100

QUANTUMAERATOR PARTS LIST, 7 1/2H.P.

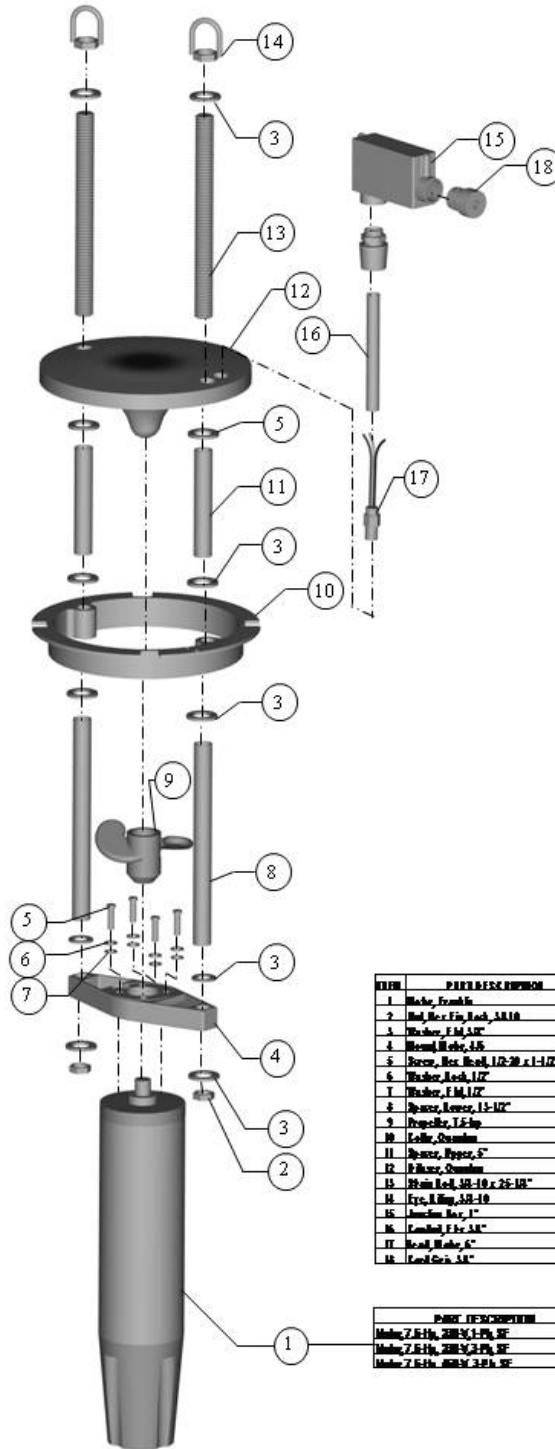

ITEM	DESCRIPTION	QTY	PART NUMBER
1	Motor, Floatless	1	80021500
2	Washer, Flat, Wash, 3/16"	2	16070616
3	Washer, Flat, 5/16"	12	16070406
4	Washer, Flat, 1/2"	1	61000416
5	Spacer, Hex. Head, 1/2-20 x 1-1/2"	4	16000526
6	Washer, Lock, 1/2"	4	16000500
7	Washer, Flat, 1/2"	4	16070616
8	Spacer, Round, 1 1/2"	2	6630136
9	Propeller, T-6 hp	1	71100000
10	Lock, Round	1	61100000
11	Spacer, Round, 5"	2	6630000
12	Flange, Round	1	8001012000
13	Flange, Round, 3/8-10 x 2 1/2-10"	2	66302020
14	Flange, Round, 3/8-10	2	16010000
15	Washer, Flat, 1"	1	16010000
16	Washer, Flat, 3/8"	12	16010000
17	Washer, Flat, 1/2"	1	16010000
18	Lock, Flat, 1/2"	1	16010000

ITEM	DESCRIPTION	QTY	PART NUMBER
1	Motor, 7 1/2 Hp, 3450 RPM, SE	1	80021500
2	Motor, 7 1/2 Hp, 3450 RPM, SE	1	80021500
3	Motor, 7 1/2 Hp, 3450 RPM, SE	1	80021500

QUANTUM AERATOR PARTS LIST, 10 H.P.

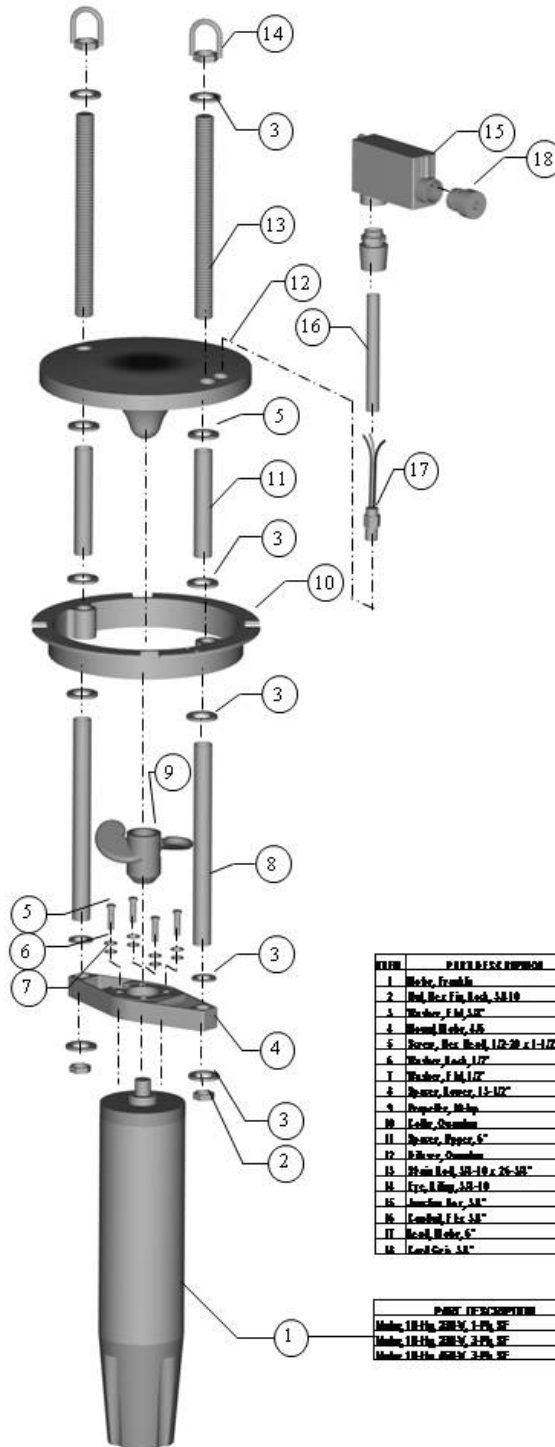

ITEM	DESCRIPTION	QTY	PART NUMBER
1	Motor, Franklin	1	Recalling
2	Nut, Hex Flt, Lock, 3/8-10	2	16912616
3	Washer, F Mt, 3/8"	12	16919106
4	Washer, 1/2"	1	6100046
5	Washer, Hex Head, 1/2-20 x 1-1/2"	4	16996526
6	Washer, Lock, 1/2"	4	16996506
7	Washer, F Mt, 1/2"	4	16919916
8	Spacer, Reverse, 1 1/2-1/2"	2	16919156
9	Propeller, 18"sq	1	1125434
10	Collar, Stainless	1	611281-6
11	Spacer, 5"	2	1691916
12	Roller, Stainless	1	169191200
13	Frame Rod, 3/8-10 x 26-1/2"	2	1691916216
14	Eye, R Wdg, 3/8-10	2	1691918
15	Anchor Bolt, 3/8"	1	169191666
16	Flange, F Mt, 3/8"	12	169191134
17	Head, Motor, 5"	1	169191901
18	Lock Wash, 3/8"	1	169191901

DESCRIPTION	PART NUMBER
Motor, 10-Hp, 208V, 1-Ph, SE	169191200
Motor, 10-Hp, 208V, 3-Ph, SE	169191200
Motor, 10-Hp, 480V, 3-Ph, SE	169191200

QUANTUMAERATOR PARTS LIST, 15 H.P.

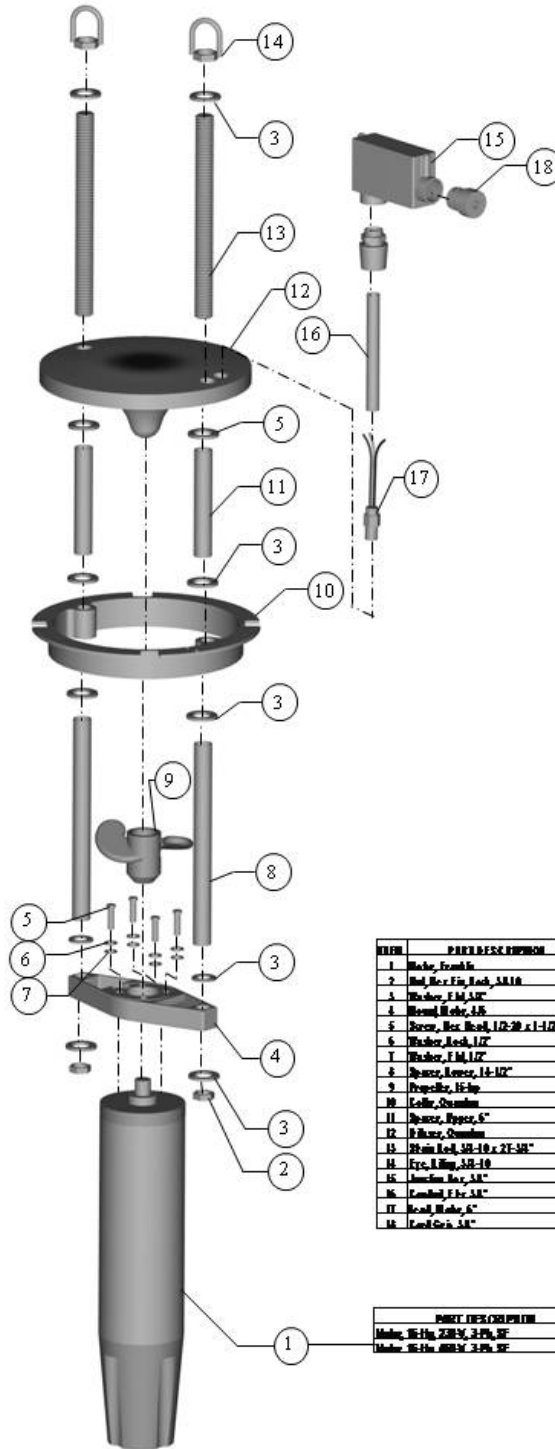

ITEM	PART DESCRIPTION	QTY	PART NUMBER
1	Motor, Frame	1	See 1 Sup
2	Wd. Hex. Fin. Wash. 3/16"	2	16070615
3	Washer, F.M. 1/2"	12	16070165
4	Washer, Hex. 1/8"	1	61000116
5	Spacer, Hex. Wash. 1/2-20 x 1-1/2"	4	16000526
6	Washer, Wash. 1/2"	4	16000509
7	Washer, F.M. 1/2"	4	16070055
8	Spacer, Hex. 14-1/2"	2	16321145
9	Propeller, 15 hp	1	TI P29 M
10	Collar, Osmunda	1	61 E84-6
11	Spacer, Upper, 6"	2	163211
12	Flange, Osmunda	1	WT F01240
13	Flange Wash. 3/8-10 x 2 1/2-20"	2	16321115
14	Flange, 3/8-10	2	163 E034
15	Terminal Box, 1/8"	1	163015066
16	Control Cable, 1/8"	15	163101134
17	Head, Motor, 6"	1	51126111001
18	Head Cap, 1/8"	1	160-310-Head

ITEM	PART DESCRIPTION	PART NUMBER
1	Motor, 15-Hp, 230-V, 3-Ph, 50	160700000
1	Motor, 15-Hp, 480-V, 3-Ph, 50	160700000



QUANTUM AERATOR PARTS LIST, 20 H.P.

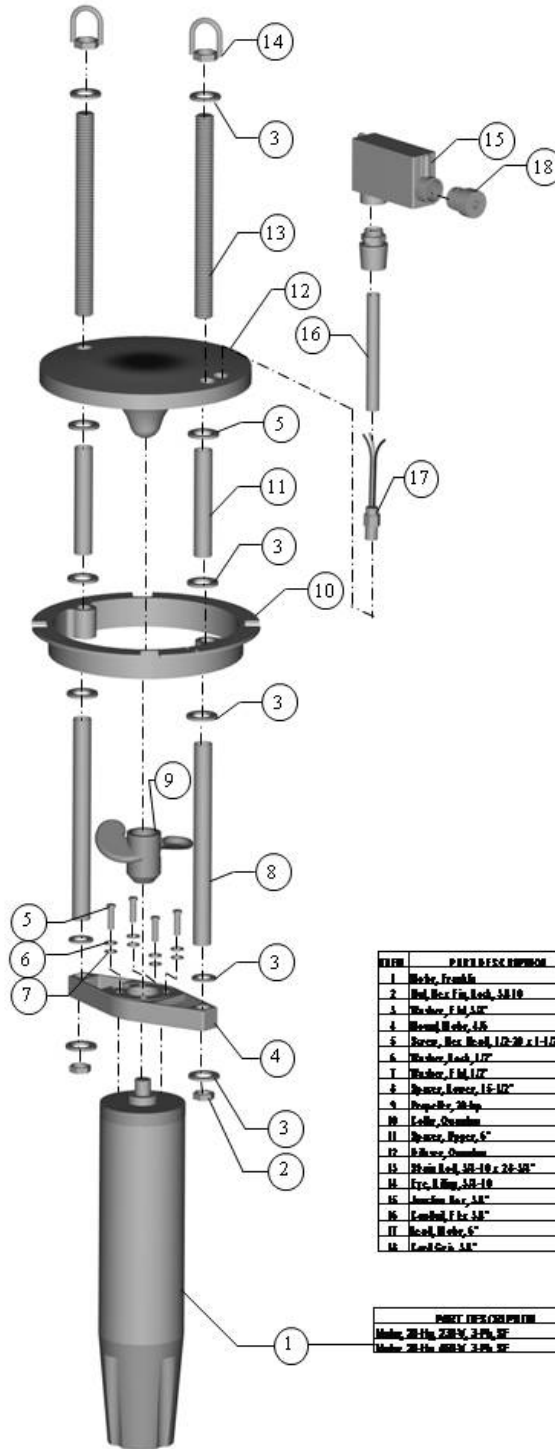

ITEM	PART DESCRIPTION	QTY	PART NUMBER
1	Motor, Frank	1	Sec. Lidg
2	Shaft, 3/8" Dia, 30" L, 30-30	2	10012615
3	Washer, F.M. 3/8"	12	10079465
4	Rotor Head, 3/8"	1	5100145
5	Rotor, 3/8" Dia, 1/2" x 1-1/2"	4	10006526
6	Washer, 3/8" Dia, 1/2"	4	10006526
7	Washer, F.M. 1/2"	4	10079955
8	Spacer, 1/2" Dia, 1-1/2"	2	0522155
9	Rotor Head, 3/8"	1	11000055
10	Collar, 3/8" Dia	1	5100145
11	Spacer, 3/8" Dia, 5"	2	0522155
12	Rotor Head, 3/8"	1	10012615
13	Shaft, 3/8" Dia, 30-30 x 22-30"	2	0522155
14	Eye, 3/8" Dia, 30-30	2	10012615
15	Washer, 3/8"	1	10012615
16	Eye, 3/8" Dia, 30-30	1	10012615
17	Head, 3/8"	1	5100145
18	Eye, 3/8"	1	10012615

ITEM	PART DESCRIPTION	QTY	PART NUMBER
1	Motor, 20 H.P., 230V, 3-Phase, 50/60 Hz	1	05000000
2	Motor, 20 H.P., 480V, 3-Phase, 50/60 Hz	1	05000000





AIR-O-LATOR CORPORATION  
8100-04 PASEO, KANSAS CITY, MO 64131  
800-821-3177 or 816-363-4242 FAX: 816-363-2322  
EMAIL: [SALES@AIROLATOR.COM](mailto:SALES@AIROLATOR.COM)  
WEBSITE: WWW.AIROLATOR.COM